

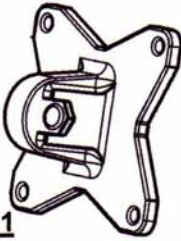







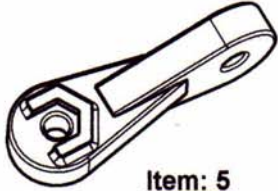

INSTALLATION INSTRUCTIONS FOR MODELS TRES ANT-CP-25 & TRES ANT-CP-50

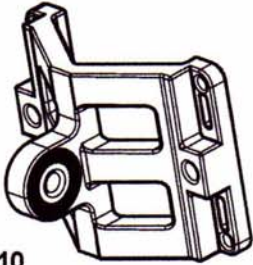
 <p>Item: 1 Antenna/enclosure base bracket Qty: 1</p>	 <p>Item: 2 Flat washer M5 Qty: 4</p>	 <p>Item: 4 Nut M5 Qty: 4</p>	 <p>Item: 5 Arm bracket Qty: 1</p>
 <p>Item: 6 Bolt M8x40 Qty: 4</p>	 <p>Item: 8 Washer spring M8 Qty: 4</p>	 <p>Item: 10 Wall/Poll bracket Qty: 1</p>	
 <p>Item: 7 Washer flat M8 Qty: 4</p>	 <p>Item: 9 Nut M8 Qty: 2</p>		
 <p>Item: 11 Clamping bracket Qty: 1 SHEET 1 OF 4</p>	 <p>Item: 12 Bolt M8x70 Qty: 2</p>	 <p>Item: 13 Bolt M5x16 Qty: 4 MT-120018/A only</p>	

14100 E. JEWELL AVENUE SUITE 12 AURORA, CO 80012
303-366-1234 (p) 303-366-1222 (f)
info@rfidinc.com www.rfidinc.com/tresbyrfidinc



INSTALLATION INSTRUCTIONS FOR MODELS

TRES ANT-CP-25 & TRES ANT-CP-50

BASE BRACKET INSTALLATION TO ANTENNA

Attach item 1 to the back of the antenna using items 2,3,4 as shown. Verify that the orientation of the hole in item 1 is aligned with the elevation axis. Use tightening torque of 5.7N/m.

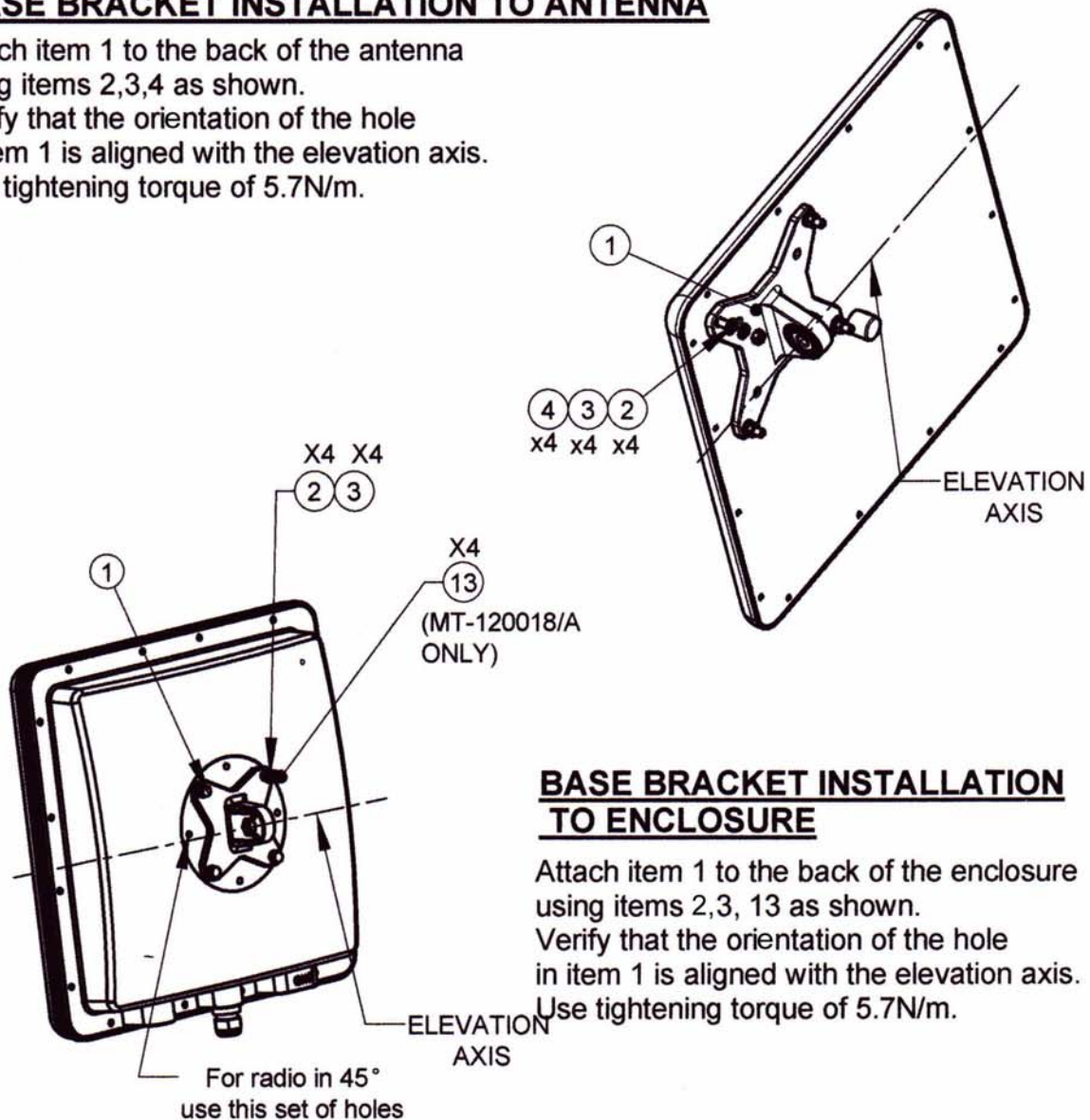

BASE BRACKET INSTALLATION TO ENCLOSURE

Attach item 1 to the back of the enclosure using items 2,3, 13 as shown. Verify that the orientation of the hole in item 1 is aligned with the elevation axis. Use tightening torque of 5.7N/m.

SHEET 2 OF 4

14100 E. JEWELL AVENUE SUITE 12 AURORA, CO 80012
303-366-1234 (p) 303-366-1222 (f)
info@rfidinc.com www.rfidinc.com/tresbyrfidinc

RFID, INC.

INSTALLATION INSTRUCTIONS FOR MODELS

TRES ANT-CP-25 & TRES ANT-CP-50

INSTALLATION ON A POLE

Step 1

Connect the base bracket as shown on page 2.

Connect item 10 to item 1 (mate knurled surfaces) using item 6,7,8,9 as shown.

Note: The bolt head shall be positioned in the socket on item 1.

Use tightening torque of 24 N/m.

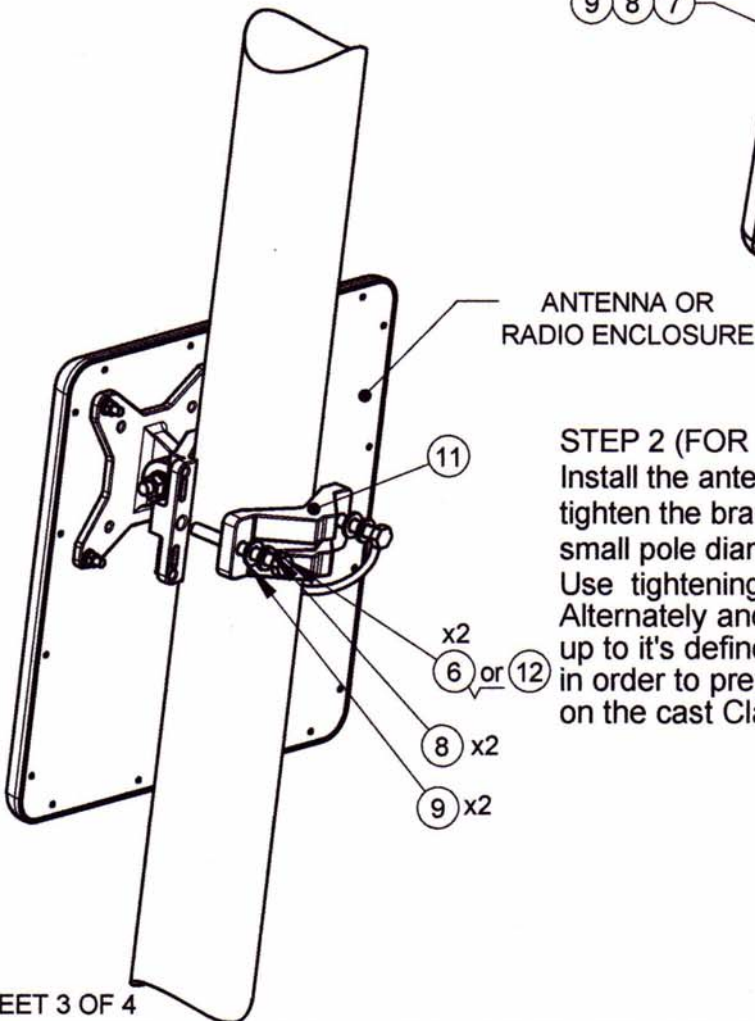
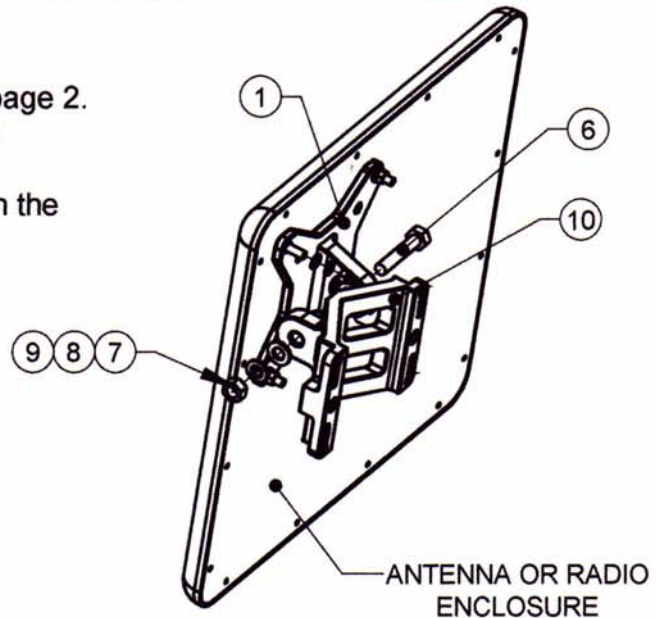

STEP 2 (FOR POLES SIZES 1.75"-3")

Install the antenna to the pole using item 11,

tighten the bracket using items 8,9,12 (for

small pole diameter use item 6 instead of item 12)

Use tightening torque of maximum 14N/m.

Alternately and equally tighten the two M8 bolts

up to it's defined tightening torque ,

in order to prevent unequal pressure
on the cast Clamps

SHEET 3 OF 4

14100 E. JEWELL AVENUE SUITE 12 AURORA, CO 80012

303-366-1234 (p) 303-366-1222 (f)

info@rfidinc.com www.rfidinc.com/tresbyrfidinc

RF ID, INC.

INSTALLATION INSTRUCTIONS FOR MODELS

TRES ANT-CP-25 & TRES ANT-CP-50

STEP 2 (FOR POLES SIZES 1"-1.75")

Install the antenna to the pole using item 11 as shown, tighten the bracket using items 8,9,12.

Use tightening torque of maximum 14N/m. Alternately and equally tighten the two M8 bolts up to it's defined tightening torque , in order to prevent unequal pressure on the cast Clamps

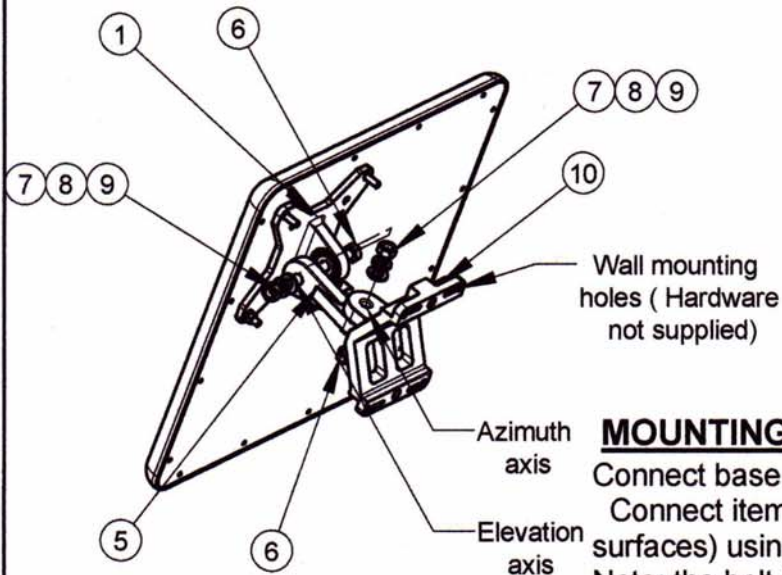
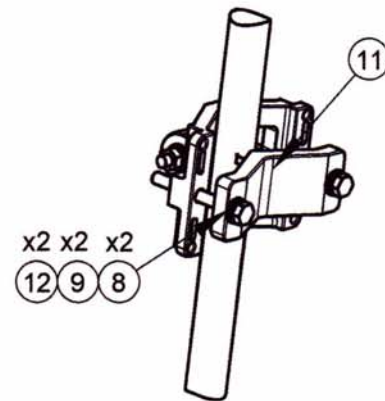

MOUNTING ON A WALL

Connect base bracket as shown on page 2

Connect item 5 to item 1 (mate the knurled surfaces) using items 6,7,8,9 as shown.

Note: the bolt head shall be positioned in the socket of item 1.

mount item 10 on the wall on the desired position. (note the azimuth axis orientation)

Attach item 5 to the arm bracket item 10 (mate the knurled surfaces) using items 6,7,8,9 as shown. Note the bolt head shall be positioned in the socket of item 5.

Use tightening torque of 24 N/m to the azimuth and elevation hardware.

SHEET 4 OF 4

14100 E. JEWELL AVENUE SUITE 12 AURORA, CO 80012

303-366-1234 (p) 303-366-1222 (f)

info@rfidinc.com www.rfidinc.com/tresbyrfidinc

RFID.INC.