



INSTALLATION AND OPERATING
MANUAL

FOR

SERIAL SIMPLEX INTERFACE

MODEL 2002
MODEL 2002E

Part No. 710-0004-01
Part No. 800-0069-00

Version 4.04

TABLE OF CONTENTS

SECTION 1 - GENERAL INFORMATION	
1.1	INTRODUCTION Page 3
1.2	DESCRIPTION Page 3
1.3	SPECIFICATIONS Page 4
SECTION 2 - INSTALLATION	
2.1	INTRODUCTION Page 5
2.2	UNPACKING AND INSPECTION Page 5
2.3	PREPARING FOR INSTALLATION Page 5
2.4	POWER REQUIREMENTS Page 5
2.5	POWER CONNECTIONS Page 8
2.6	READER WIRING Page 9
2.7	READER CONNECTIONS Page 10
2.8	ABOUT ENABLE & ENABLE REMOTE Page 10
2.9	ABOUT SHIELDING Page 11
2.10	MATING THE INTERFACE TO A COMPUTER Page 11
2.10.1	SERIAL PROTOCOL & DOCUMENTS Page 12
2.10.2	ASCII FORMAT Page 12
2.10.3	DATA TRANSFER RATES, BAUD Page 13
2.10.4	SERIAL CABLING Page 13
2.10.5	SERIAL CONNECTION Page 14
2.11	DEFAULT OPERATING MODE Page 14
2.12	INSTALLATION COMPLETE Page 15
SECTION 3 - OPERATION	
3.1	INTRODUCTION Page 16
3.2	THEORY OF OPERATION Page 16
3.3	DATA PROTOCOL Page 16
3.4	ISSUING COMMANDS TO THE INTERFACE Page 16
3.5	INTERFACE RESPONSES Page 19
3.5.1	TAG DATA Page 19
3.5.2	ERROR MESSAGES Page 20
3.6	WARRANTY Page 21

If you are reading a PDF version of this manual you may notice page numbers and the above contents to be off by a page from time to time. The conversion to Acrobat has a tendency to move sections, as the fonts don't translate perfectly.

SECTION 1 GENERAL INFORMATION

1.1 INTRODUCTION

This manual provides information pertaining to the installation and operation of the Model 2002 Serial Interface (RFID, Inc. Part No. 710-0004-01) and Model 2002E (the E signifying enclosure) (RFID, Inc. Part No. 800-0069-00).

1.2 DESCRIPTION

The Interface Model 2002 is termed Simplex because it manages only one Reader and Antenna. The Interface Model 2002 provides a full-duplex, asynchronous bit serial data stream that will interface to various equipment compatible with RS-232-C or RS-422-A specifications. The Interface is configured as Data Terminal Equipment (DTE).

The 2002 amplifies, filters and detects the data signals relayed by any of its compatible Readers (Models 1840, 1840E, 1841, 1880 or 1880E) and converts that data into a serial string. Basically, the Interface provides RF to digital translation of the signal produced by RFID, Inc.'s RF Electronic Labels, which are referred to as "Tags", when placed in the proximity of a Reader Antenna. Advanced error detection algorithms provide error-free operation. All messages are transmitted in printable ASCII characters in transmit-on-receipt or polled mode.

Via the serial connection, over which Tags are reported, the Interface can also be commanded to buffer Tags, report multiple Tag readings, repeat the last message, test itself, reset, or delete specified Readers from its polling loop.

The Eurocard format paired with the single supply voltage requirements simplify its integration into existing installations. Connection to the Reader is made using low-cost shielded twisted pair cables and angle entry terminals simplify installation.

1.3 SPECIFICATIONS

Protocol:	Full-duplex; RS232 or RS422 Selectable stop bits, parity sense, and word length
Serial Baud Rate:	Selectable, 1200, 2400, 4800, 9600, 19200, 38400, 57600, 115200
Processing Speed:	Up to 24 readings/sec.
Data Storage:	2 readings
Error Rate:	Less than 1 in 10 to the 14 th readings
Connectors	
Serial:	DB-25S
Power:	64-pin DIN 41612 Type C
Readers:	5 position screw type terminal strip
Cabling Distance to Readers:	Up to 5000 feet, total (with shielded twisted pair shielded cable)
Power Requirements:	+5 VDC +/- 5% @250 mA. (max.)
Temperature Range	
Operating:	-40 to +70 degrees C
Non-operating:	-55 to +85 degrees C
Dimensions	
Model 2002:	7.0" x 3.9" x 6.6"
Model 2002E:	9.0" x 5.1" x 1.7"
Weight	
Model 2002:	5.5 oz.
Model 2002E:	1.24 lbs

SECTION 2 INSTALLATION

2.1 INTRODUCTION

This section contains information for unpacking, inspecting and installing, and configuring the Interface, including power and signal wiring, and rating power supplies. Installation also includes matching and connecting the Interface to the Host Computer or Terminal.

2.2 UNPACKING AND INSPECTION

If the shipping carton is damaged or shows evidence of abusive handling, inspect the Interface for visible damage including dents, scratches, etc. If the unit appears damaged, contact the carrier and RFID, inc. Sales or Customer Service Departments immediately. Keep the shipping and packaging material for the carrier's inspection. RFID, inc. will arrange for repair or replacement of the damaged unit without waiting for the claim settlement with the carrier.

2.3 PREPARING FOR INSTALLATION

The power is provided through the 64 pin DIN connector and signal connections are made via a terminal strip on the printed circuit board. If the RFID, inc. enclosure assembly is not provided for the Eurocard, you must provide a Eurocard DIN connection with +5v on pins a1,c1, and ground on pins a32, c32. To access the inside of the Model 2002E assembly, remove the end plates and remove the printed circuit board assembly. The end plates may be removed by first removing the four corner hex nuts on each end plate which secure it to the assembly. Refer to the Figure 2-1.

Following installation of all Reader wiring, the end plates should be reinstalled using the same screws. The cable gland should be tightened to secure and seal the wiring.

2.4 POWER REQUIREMENTS

The Interface must be powered from a regulated power source (linear supplies are acceptable, switching supplies are out of the question) having the following characteristics:

Voltage DC	Voltage Range:	4.75 to 5.25 volts	
	Ripple:	70 mV p-p (max.)	
Current	Operating:	250 mA. (max.)	100 mA. (typ.)

RFID, Inc. can provide a power supply suitable for use with the Model 2002. The Interface should be operated from a grounded supply that has the same ground reference as the host computer. The ground reference used for the Readers may be of a different origin.

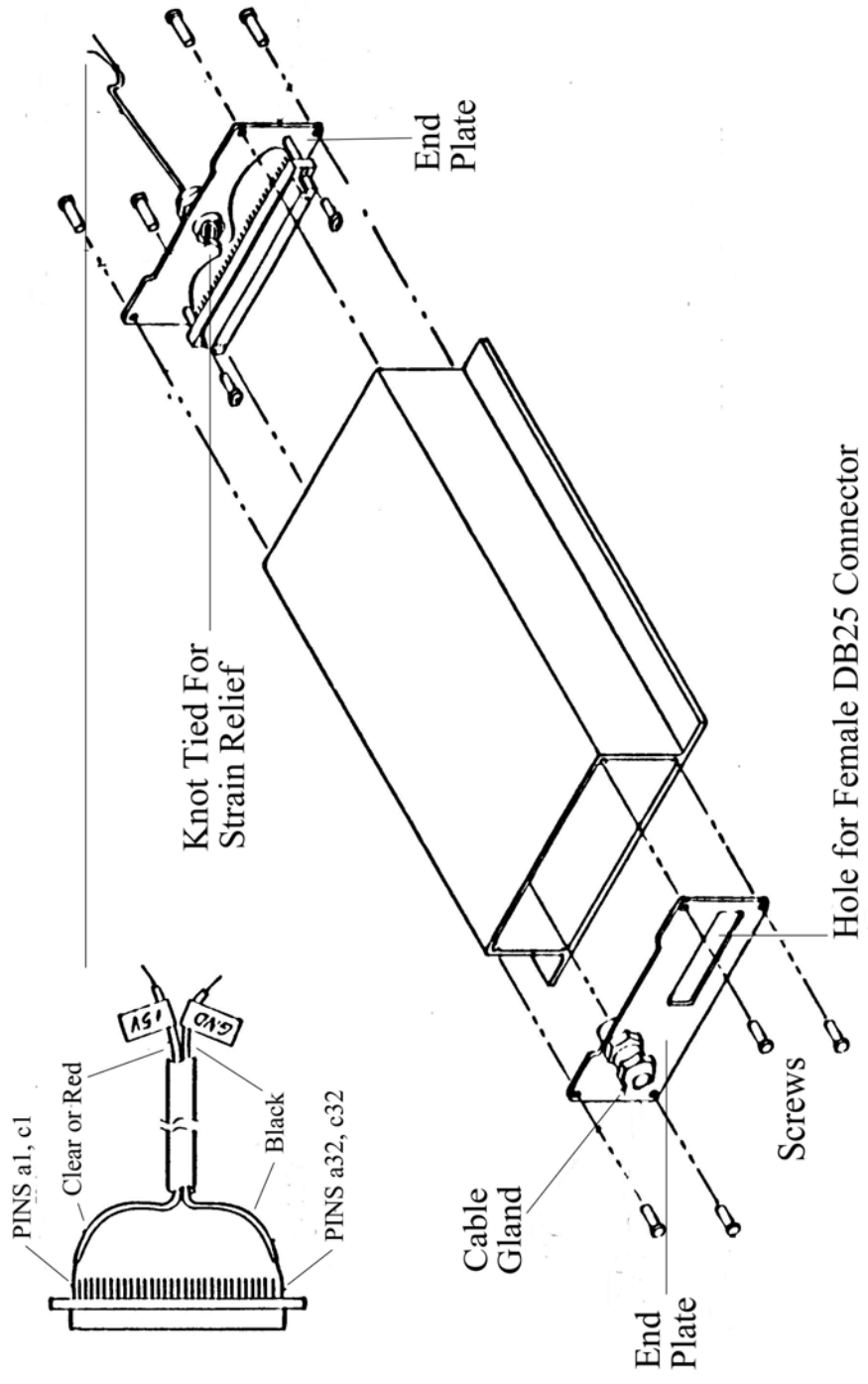

Figure 2-1

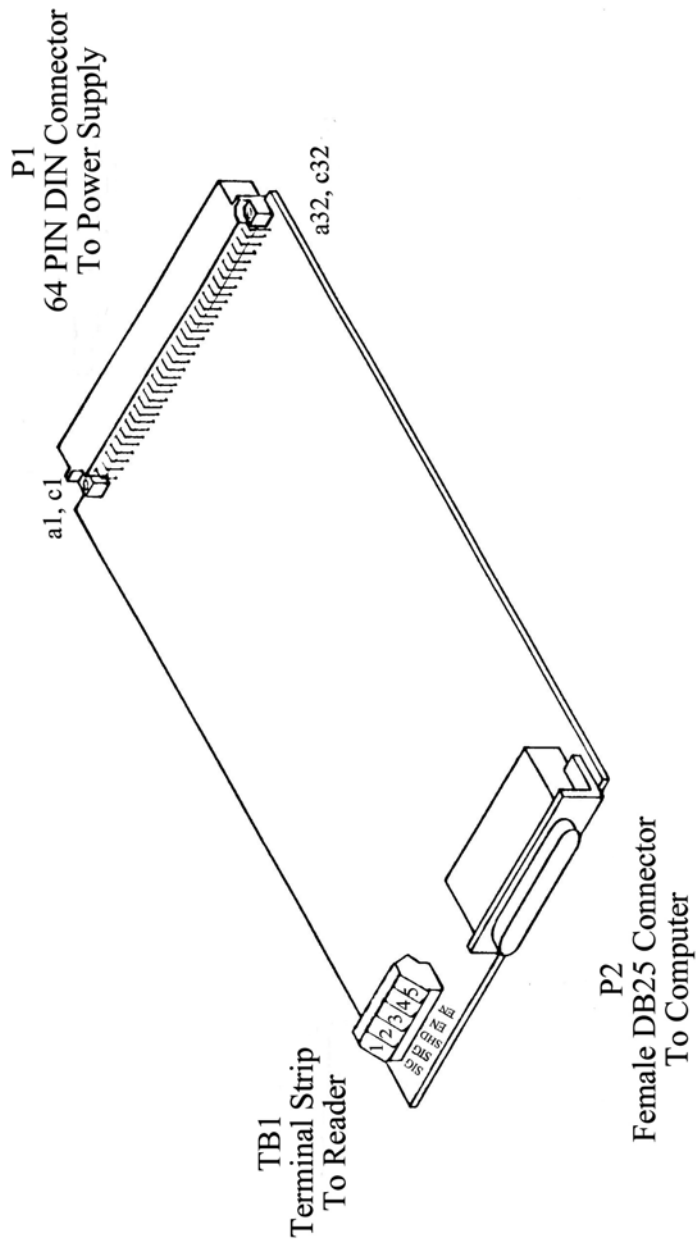

Figure 2-2

2.5 POWER CONNECTIONS

On the Model 2002E, power wiring is already threaded through the cable gland and connected to the solder tail DIN connector (P1) on the circuit card. There should be a knot in the wire to provide strain relief. Wires should be connected in accordance with the following:

TABLE 2-1 POWER CONNECTIONS

<u>DIN Connector (P1)</u> <u>PIN NUMBER</u>	<u>CONNECTION</u> <u>FROM DC SOURCE</u>
a1,c1	+5v
a32,c32	DC Return (GND)

WARNING

The power source should be turned off while making connections to the reader. It is recommended that the power source remain off anytime the circuit board is removed from its enclosure assembly.

Power connection to the Interface should be made with the power source turned off. There is no onboard over current protection so an external fuse is recommended to protect the power supply if it has no over current protection of its own.

If the Interface is to be used without an enclosure, these mating DIN connectors are recommended for connection of the power wires:

Panduit 100-964-454
Elco 208457096008026
Weidmuller 914605

If the Interface is to be housed in a back plane, make sure that pins a,c2 - a,c31 are left unconnected. These pins are connections to the processor's data bus and can affect the Interface's operation if improperly connected.

A note about power cable length: Long power cables will produce voltage drops resulting in a lower voltage at the Interface end than at the power supply end. There is no inherent limit to the length of wire from the supply to the Interface as long as the high and low voltage specifications are maintained at the Interface.

2.6 READER WIRING

This section describes the signal (and enable if used) wiring that connects the Interface to the Reader. The two SIGNAL wires provide the path for RF data from the Readers into the Interface. The two ENABLE wires provide multiplex control from the Interface to the Readers. For best performance, shielded, #14 to #28 AWG, insulated, stranded wire is recommended and all wires should be stripped approximately 3/8 inch and tinned. The following cables are recommended:

TABLE 2-2 RECOMMENDED CABLES

<u>APPLICATION</u>	<u>CABLE DESCRIPTION</u>	<u>RECOMMENDED TYPE</u>
Signal Only	Cable, Paired, 2 Conductor #22 AWG with foil shield Polyethylene & PVC, 60 Deg C	RFID 214-2202-00 Columbia C2514 Manhattan M13226 Belden 8761
Signal and Enable	Cable, Paired, 4 Conductor #22 AWG (1 Pr.) with foil shield #22 AWG (1 Pr.) unshielded Polypropylene & PVC, 60Deg C	RFID 214-2204-00 Alpha 2464 Manhattan M4451 Belden 8724
Signal and Enable and Power	Cable, Paired, 6 Conductor #24 AWG (2 Pr.) with foil shield 22 AWG (1 Pr.) unshielded PVC, 80 Deg C	RFID 214-2206-00 Manhattan M14477 Belden 8786

Whatever cable is selected should fit within the range allowed by the cable gland providing wire access to the reader. The cable gland will accommodate diameters of .090 to .265 inches.

A note about "PLENUM" cabling, plenum cable eliminates the need for using conduit when installing cables in air plenums. In typical modern buildings, a plenum exists between the drop ceilings and the floors that support them. Because these air ducts often run across an entire story they can be a convenient place to run cable, but they can also be an invitation to disaster if fire breaks out. Fire and smoke can spread rapidly throughout the air duct system if the fire is able to feed on combustible materials. The cables designated Plenum are approved by the NEC and UL because of their flame-resistant and low smoke emission properties. While Plenum cable costs more than conventional cable, the overall installed cost is generally less because it eliminates the need for conduit installation.

PLENUM

Cable, Paired, 2 Conductor, Belden 89182
#22 AWG with foil shield, NEC 725, Class 2 classified

2.7 READER CONNECTIONS

On the Model 2002E, wiring should be fed through the cable gland and connected to the angle entry terminal strip (TB1) on the circuit card. Wiring should be connected in accordance with the following:

TABLE 2-3 READER CONNECTIONS

TERMINAL STRIP (TB1) PIN NUMBER	NOMENCLATURE ON PCB	CONNECTION
1	SIG	SIG on Reader
2	<u>SIG</u>	<u>SIG</u> on Reader
3	SHD	Do not connect here if if connected on the Reader
4	EN	EN on Reader
5	<u>EN</u>	<u>EN</u> on Reader

2.8 ABOUT ENABLE AND REMOTE ENABLE

Although the Model 2002 Interface is used only with a single Reader and Antenna, the Enable function is an option in place that can be employed by the user to turn the Reader on and off, if desired. The Reader operation may be controlled (enabled, disabled) from the Interface via the enable outputs (EN, EN return or not) to the Reader. This is termed remote enable. If the remote enable feature is not used, a shorting jumper or shunt should be placed across J1 on the circuit board of the Reader assembly. The shunt overrides the remote enable control and continuously enables the Reader. The Reader is normally supplied with the shorting shunt installed on J1. Refer to your Reader manual for specific instructions.

The typical circuit connection for the remote enable feature is shown in Figure 2-3.

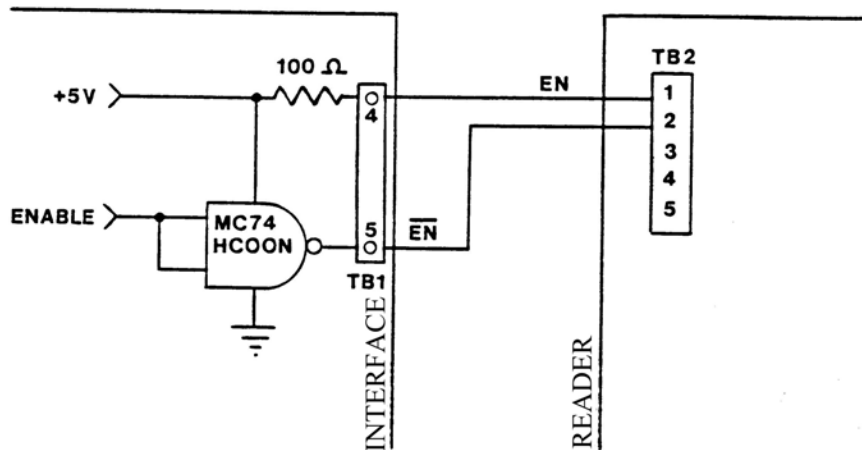

Figure 2-3

2.9 ABOUT SHIELDING

Shielding is recommended for both signal and enable wiring especially if long lengths of wire are used, or when operating in an environment of high electromagnetic noise. Each wire's shield should be connected at only 1 point, connecting both ends of a shield will produce a closed loop in which noise has no way to exit. A daisy chain connecting multiple Readers counts as a single wire, and the shields should be connected together, but not to the Reader, at each drop along its run. Since shield connections are recommended at the source of the associated signal, SIGNAL shields are connected to Readers and ENABLE shields are connected to the Interface. If the SIGNAL wires are combined in the same cable with the ENABLE wires their shields are common and connected to one Reader. There is an excellent wiring drawing contained in both the Model 1845 and 1885 manuals.

2.10 MATING THE INTERFACE TO A COMPUTER - THE SERIAL CONNECTION

Communication characteristics, speed, parity, and number of bits per character, must be matched between the Interface and the connected host. If the Interface is talking at 2400 baud (bits per second) and the host at 4800, they'll never understand each other. Most hosts can be configured to a number of different speeds and formats. Some, however, cannot. That's why the Interface can be set to operate from 1,200 to 115,200 baud. If your host is stubborn, match the Interface to the host's

settings. If your host is flexible, the highest baud is recommended with 7 bits per word and 1 stop bit so the Interface can spend less time communicating and more time looking for Labels. Parity, either even or odd, is recommended for reliability and RS-422 is more reliable than RS-232 but is generally less available for a variety of hosts. RS-232 guidelines recommend not exceeding 50' in cable length, whereas RS-422 can be run 5000'.

2.10.1 SERIAL PROTOCOL AND APPLICABLE DOCUMENTS

- EIA Standard, RS-232-C August, 1969
- EIA Standard, RS-422-A December, 1978
- RFID, inc. Interface Specification 710-0004-021

2.10.2 ASCII FORMAT

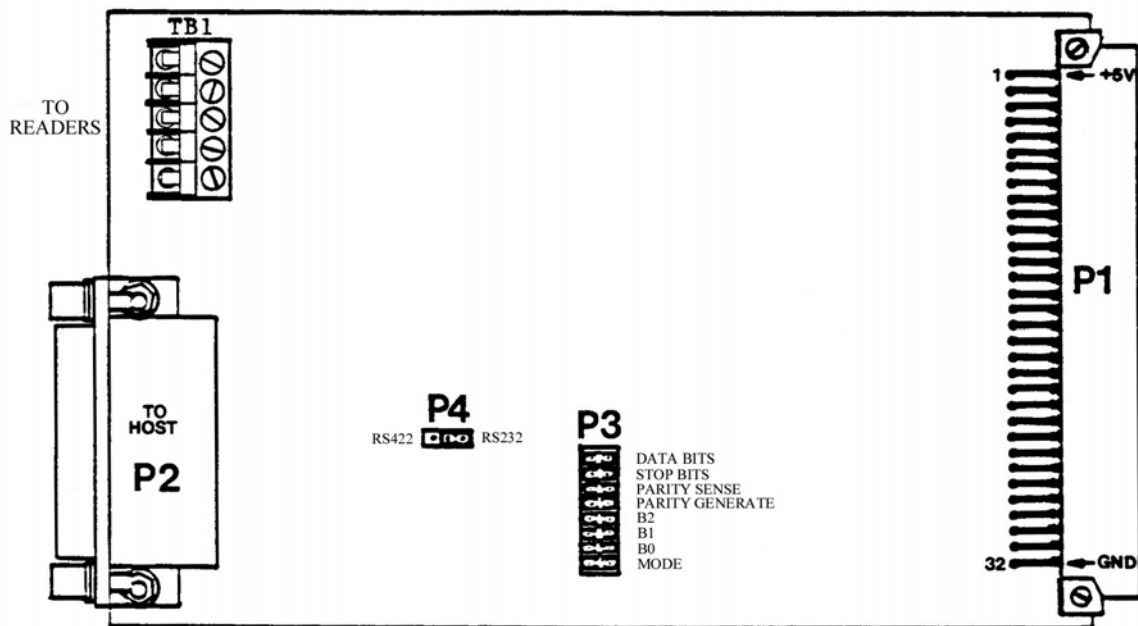

FIGURE 2-3 JUMPER SELECTIONS

The transmitted data (TD) and received data (RD) are transferred using the format as determined by jumper selection (P3) on the Interface card. The format, data bits per character, number of stop bits, and parity, is set with the top 4 jumpers on P3. Default communication characteristics are set by installing or removing the jumpers. Thus shorting together or leaving the pin pairs open.

The "removed" jumpers may be left on a single pin so they won't become misplaced should someone want to change the configuration at a later date. The position of the P3 jumpers is read at reset so configuration changes are not registered until a subsequent power up or software reset.

These positions are labeled: 7B for 7 bits, 2S for 2 Stop bits, EV for Even parity, and ON for parity on.

If the jumper is on, then these labeled formats are true. If the jumper is off, then the alternate format selection is true. See the table below.

LABEL	PARAMETER	JUMPER	
		ON	OFF
7B	Data Bits per Character	7	8
2S	Stop Bits per Character**	2	1
EV	Parity Sense (if ON)*	Even	Odd
ON	Parity Generate and Receive	On	Off

* If Parity is Off, no parity is generated or checked regardless of the position of the Parity Sense jumper.

** If Parity is ON and 8 bits per character is selected, one stop bit is transmitted regardless of the Stop Bit jumper.

2.10.3 DATA TRANSFER RATES, BAUD

The Interface's baud rate is set with the bottom 3 jumpers of P3. Baud transfer selections range from 1200-115200. The Interface requires up to 800 microseconds to process received characters; accordingly, it may be necessary to provide a delay between characters transmitted to the Interface at the highest baud rates. All possible combinations of the 3 jumpers, on or off, result in the following 8 possible baud rates:

Baud Rate	P3 Jumpers:	B2	B1	B0
1200		OFF	OFF	OFF
2400		OFF	OFF	ON
4800		OFF	ON	OFF
9600		OFF	ON	ON
19200		ON	OFF	OFF
38400		ON	OFF	ON
57600		ON	ON	OFF
115200		ON	ON	ON

P5 Jumper, leaving the shunt off defaults the Interface to 16 Tag bytes of ASCII characters. Placing the shunt on defaults the Interface to 32 Tag bytes of ASCII characters.

2.10.4 SERIAL CABLING

The Model 2022 Interface connects to the host via 25-pin, female "D" connector - P2. Therefore, a cable with a 25-pin, male "D" connector on one end and the appropriate connector required for the host on the other end must be built or purchased.

Determine which type of equipment you have for your host. Any one of these combinations will suffice.

* If you have Data Communications Equipment (DCE) with a female DB25 connector, use a DB25 male/male cable assembly. RFID can provide this component, P/N 730-0001-xx, with the last 2 digits indicating your desired cable length in feet.

* If you have DCE with a male DB25 connector, use the above indicated cable assembly and a female/female connector adapter that is a gender changer.

* If you have Data Terminal Equipment (DTE) with a male DB25 connector, use the cable assembly and a connector adapter modem eliminator (RFID P/N 730-0003-00). The modem eliminator switches the activity on pins 2 & 3, so that they do not transmit and receive on the same lines.

* If you have DTE with a female DB25 connector, you must again use the cable assembly and the connector adapter modem eliminator. You must also utilize a female/female connector adapter to change the gender of the DB25 connector.

2.10.5 SERIAL CONNECTION

The Interface is configured as Data Terminal Equipment (DTE) meaning that it transmits its data on pin 2 and receives data on pin 3. Conversely, a Data Communication Equipment (DCE) device receives on Pin 2 and transmits on Pin 3. Since most terminals and IBM-PC compatible interfaces are also configured as DTE, the interface cable will probably have to connect the Interface's pin 2 to the host's pin 3 and the Interface's pin 3 to the host's pin 2. There exist simple converters called modem eliminators, which accomplish this, discussed in the section above. Since RS-232 and RS-422 pin designations are not standardized, check your host's operating manual for verification. The important thing is to connect the Interface's Transmit Data (TD) signal (pin 2) to the host's Receive data (RD) signal, the Interface's Receive Data (RD) signal (pin 3) to the host's Transmit Data (TD) signal, and the Interface's Ground (pin 7) to the host's Ground. The table below lists the signals present on the Interface's DB-25 connector P2 and their usage for each of the possible RS interface standards.

<u>PIN#</u>	<u>SIGNAL NAME</u>	<u>DIRECTION</u>	<u>RS232</u>	<u>RS422</u>
2	TD - Transmitted Data	From Interface	R	R
14	TD* - Inverted TD	From Interface	U	R
3	RD - Received Data	To Interface	R	R
16	RD* - Inverted RD	To Interface	U	R
7	GND - Signal Ground	-	R	R
25	+5V - Power			

Usage Symbols: R - Required for this configuration
 U - Unused in this configuration

2.11 DEFAULT OPERATING MODE

The remaining jumper on P3, "M2", directs the Interface to select between Polled or Non-polled operation. Mode 2 or polled operation is selected if this jumper is on at reset and causes the Interface to buffer Tags until a transfer command is received from the host. Mode 1, selected if the jumper is removed, causes the Interface to transmit its detected Tag data once immediately upon detection. There is a Mode 3 discussed later that can only be selected through a software command. The default mode can also be changed by the host via a Mode Command, discussed in the third section of this manual.

2.12 INSTALLATION COMPLETE - POWER UP MESSAGE

Installation should now be complete. You can see how you did by preparing the host for communication and applying power to the Interface. Whenever the Interface is powered up or reset, it issues a power up message. The issuance of this message signifies to you at least one-way communication, the transmission function, is working properly and also advises the host that a reset has occurred so it can reset any non-default operating characteristics, assuming you include this in your software. The power up message is preceded by a Line Feed (<LF>) and followed by a Carriage Return (<CR>) like all messages out of the Interface. For the Model 2002, the power up message consists of an 18 character string:

ELECTRONIC-LABEL**

For the Model 2002, 8 character devices, the power up message consists of a 10 character string:

RFID-LABEL

To test communication from the host to the Interface, issue a Carriage Return. The response you get should be that of a question mark.

SECTION 3 OPERATION

3.1 INTRODUCTION

This section explains operating information for the Interface. It describes its theory of operation, timing, commands, operating modes, and responses. To issue commands to the unit, always use capital letters as the unit recognizes only capitals.

3.2 THEORY OF OPERATION

The Interface has 3 main functions: 1) monitor the SIGNAL inputs from the Readers for the presence of Electronic Tag data, 2) generate pulses on the ENABLE lines to control the Readers so that only one is enabled at any time, (Model 2022 only) and 3) communicate over the serial interface to meet the specific needs of the user.

3.3 DATA PROTOCOL

The data protocol utilizes ASCII characters for all data from the Interface and all control functions from the host computer. Each message includes delimiters at the start and end of message. Delimiters used for messages from the Interface are Line Feed (<LF>) at the start of message and Carriage Return (<CR>) at the end of message. For Commands into the Interface, the start of message delimiter may be either Line Feed (<LF>) or a left hand bracket ([) and the end of message delimiter may be either Carriage Return (<CR>) or a right hand bracket (]).

The protocol allows the Interface to be connected to a variety of computer systems, printers and terminals. Since special ASCII control characters are avoided, software in the host computer can be written in higher level languages without the need for special device driver routines or middleware.

3.4 ISSUING COMMANDS TO THE INTERFACE

All commands must be issued in CAPS. There are eight commands by which the Host Computer can control the operation of the Interface. These commands are:

M#	MODE CONTROL
T	TRANSFER REQUEST
S	SYSTEM RESET
B	BUFFER RESET
O	STROBE ON
N	STROBE OFF
I	INITIATE SELF TEST

R REPEAT MESSAGE

MODE CONTROL COMMAND - [M#]

Type this: [M#]

This command switches the Interface between its various operating modes.

Mode #1 - [M1] Single Report, Transfer on Receipt

The Interface continually scans for Tag reads via the Reader and transfers the information immediately to the host system, once.

Mode #2 - [M2] Polled Operation

This mode also continually scans the Reader for Tag reads, but stores the data for subsequent retrieval when requested by the host computer. Due to limited processor memory, only two Tags can be buffered by the Interface, therefore, care must be taken to ensure that the Interface is polled frequently enough that no Tags are missed because of full buffers. To request this stored information use the command the Transfer Request Command.

Mode #3 - [M3] Report Duplicate Tags

This Mode continually scans for Tag reads via the Reader and transfers the information immediately to the host system, repeatedly, as long a Tag is detected in the Reader/Read Head's signal field. The only exit from Mode 3 is via the System Reset command or by cycling power.

The default Mode is set during Reset or Power Up according to jumper M2 at PCB address P3. The default mode may be changed via these commands.

TRANSFER REQUEST COMMAND - [T]

Type this: [T]

The Transfer Request is used in Mode 2 to instruct the Interface to transmit a single Tag's data. If a Tag has been detected since the last Transfer Request, its data will be transmitted along with the Reader identifier in the standard format. If a Tag has not been detected, an Empty Buffer message - "e" will be transmitted. It is recommended that at least 70 milliseconds occur between Transfer Requests to allow the Interface to search for Tags. It is also recommended that consecutive Transfer Requests be issued until receipt of the "e" - Empty Buffer Message. The Interface keeps the last message transmitted in its on-board memory in case a transmission error is detected by the host and it requests a retransmission. Due to limited memory, this Tag retention takes up one Tag buffer. Issuing subsequent Transfer Requests effectively acknowledges the successful reception of the last Tag transmitted and frees up that memory for Tag data.

If received by the Interface while it is in Mode 1 or 3, the Transfer Request will cause a "?" - Invalid Command message to be issued by the Interface.

SYSTEM RESET COMMAND - [S]

Type this: [S]

The System Reset command causes the Interface to perform a software reset clearing all buffers, reverting to all default settings per jumpers at P3 and P4, setting the access key to its default value FFFF, enabling all Readers, and issuing the power up message. Any previously reported Tags that are still in Reader Antenna range will be reported again. The start up message "ELECTRONIC LABEL" will appear again.

BUFFER RESET COMMAND – [B]

Type this: [B]

Upon completion of the current transmission, the Interface clears all current buffered Tag data. The Buffer Reset Command allows the reporting of a previously reported Tag if re-detected. In Modes 1 and 2, Tags are detected multiple times but reported only once per detection at a given Reader. If the Tag is removed from the field for two seconds or more, then re-introduced, it is re-reported without this command. This command allows the same Tag to be re-reported at the designated Reader without being removed for two seconds.

STROBE OFF COMMAND – [O]

Type this: [O]

In all modes, the Interface turns off the Reader output via the REMOTE ENABLE signal. This command is for conserving energy.

STROBE ON COMMAND – [N]

Type this: [N]

In all modes, the Interface turns on the Reader output via the REMOTE ENABLE signal.

INITIATE SELF TEST COMMAND – [I]

Type this: [I]

The Interface performs a comprehensive self test, indicates its Mode status, and displays its firmware version. The internal tests performed are of the ACIA - communication circuitry, RAM - internal memory, ROM - program memory, and the processor's internal timer. The results of each test are transmitted as they are completed with a "1" indicating the successful completion of a test and a "0" indicating failure. If any of these tests fail, contact RFID for corrective action.

Successful self test will read as follows:
"11111111(Vn.nn)" for Modes 1 & 2 and "10111111 (Vn.nn)" for Mode 3,
followed by the System Reset, "ELECTRONIC LABEL".

The first nine characters represent in order:

ACIA test
Duplicate Tag test (0 = Mode 3, 1 = Mode 1 or 2)
Not used
RAM test
ROM test
Timer test
Not used
Not used

Firmware release version followed by M(Vn.nn) where n.nn is the release number.
A SYSTEM RESET follows this transmission.

Following the transmission of the Self Test message, the processor goes idle to allow the system "WATCHDOG" to generate a hardware reset. This reset should generate a power up message. Failure to receive the power up message should be regarded as a problem that should be corrected before the Interface can be reliably used.

The WATCHDOG is a circuit that must be continually pulsed by the microprocessor's firmware. If the microprocessor gets hung up due to a power surge or processor failure it will automatically reset itself. The idle mode at the end of the Self Test tests this feature.

REPEAT MESSAGE COMMAND – [R]

Type this: [R]

The Interface repeats the previous transmitted message. This command must be processed before a new transmission is begun. If the Tag buffer is refilled by a new Tag before the REPEAT MESSAGE command is processed, a Tag buffer empty message, 'e', is transmitted.

3.5 INTERFACE RESPONSES

3.5.1 TAG DATA

RFID, Inc. Tags can be programmed with 8 or 16 characters, but 16 characters is used herein:

A Tag will report as <LF># xxxxxxxxxxxxxxxx<CR> where the # symbol represents the Reader address where the Tag was detected, followed by an ASCII space.

In the case of an 8 character Interface Model 2022/8, Tags may only be programmed with the ASCII representations of 0-9 A-D.

In the case of a 16 character Interface Model 2022, Tags may be programmed with the ASCII representations detailed in the Valid Tag Character Set table below, also listing hex value.

@	40	0	30	A	41	P	50
!	21	1	31	B	42	Q	51
“	22	2	32	C	43	R	52
#	23	3	33	D	44	S	53
\$	24	4	34	E	45	T	54
%	25	5	35	F	46	U	55
&	26	6	36	G	47	V	56
‘	27	7	37	H	48	W	57
(28	8	38	I	49	X	58
)	29	9	39	J	4A	Y	59
*	2A	:	3A	K	4B	Z	5A
+	2B	;	3B	L	4C	[5B
,	2C	<	3C	M	4D	\	5C
-	2D	=	3D	N	4E]	5D
.	2E	>	3E	O	4F	^	5E
		/	2F	?	3F		

3.5.2 ERROR MESSAGES

In addition to the Power up message, Self-test results, and Tag data previously discussed, the Interface also generates the following messages:

- r - Repeat Last Transmission
- ? - Invalid Command
- e - Empty Buffer

All messages out of the Interface are preceded by a Line Feed and followed by a Carriage Return to provide proper screen formatting.

The "r" - Repeat Last Transmission message indicates that the Interface observed a transmission error on the last command received. Since an error was detected the command was not processed and must be repeated by the host.

The "?" - Invalid Command message indicates that the Interface detected a problem with the last command issued. The Invalid Command message is issued upon reception of the End of Message delimiter when one of the following errors has been detected:

Illegal delimiter format - the receipt of a message not preceded by a start delimiter and followed by an end delimiter.

Illegal command between delimiters - the receipt of a message not contained within this specification.

Legal but invalid command received - i.e. the receipt of [T] Transfer Request while in Mode 1.

The "e" - Empty Buffer message is issued by the Interface in Mode 2, following a [T] Transfer Request when no Tag has been detected. The Empty Buffer message is issued in Mode 1 when a Repeat Message command is received after the last transmitted Tag has already been replaced in the Interface's Tag buffer by a new Tag.

3.6 WARRANTY

RFID, Inc. products are warranted against defects in materials and workmanship for one (1) year from date of shipment. RFID, inc. shall, at its option, either repair or replace products that prove to be defective and are returned with freight prepaid to RFID, inc.'s plant within the warranty period. The foregoing warranty shall not apply to defects resulting from abuse, misuse, accident, alteration, neglect or unauthorized repair or installation. RFID, inc. shall have the right of final determination as to the existence and cause of the defect.

THE WARRANTY SET FORTH ABOVE IS EXCLUSIVE AND NO OTHER WARRANTY, WHETHER WRITTEN OR ORAL, IS EXPRESSED OR IMPLIED. RFID, inc. SPECIFICALLY DISCLAIMS THE IMPLIED WARRANTIES OR MERCHANTABILITY AND FITNESS FOR A PARTICULAR PURPOSE.

The remedies provided herein are Buyer's sole and exclusive remedies. In no event shall RFID, inc. be liable for direct, indirect, special, incidental or consequential damages, (including loss of profits) whether based on contract, tort, or any other legal theory.